

## ALSI CheckMark™ Sludge Dryer Vacuum Heat of Compression Dewatering System



**AIR and LIQUID SYSTEMS, Inc.**

The ALSI Consolidation Dewatering System offers cost effective and continuous paint sludge collection, consolidation, heat recovered dewatering and removal. ALSI equipment designs are compatible with all suspension/flotation chemical programs.

ALSI design objectives are to optimize scrubber efficiency, reduce disposal costs, provide sludge ready for recycling and minimize booth downtime for cleaning.

ALSI systems have been online since the early 1980's. Our track record includes installations of all sizes and complexities.



### System Design Review

ALSI engineers examine the entire system, whether new or retrofit. We analyze the chemical program, solids loading, and hydraulics to provide the economical, engineered solution for sludge removal suited to your plant requirements.

1. **Hydraulics Review:** in-depth study of system flow characteristics and their impact on equipment sizing.
2. **Roughing Screen:** simple, cleanable, large debris removal.
3. **Flotation Zone:** solids loading and mass balance are compared to flotation chemical efficiency.
4. **Autoweir:** patented, self-adjusting, solids concentrator is utilized to maximize tank/pit efficiency and minimize consolidator sizing.
5. **Suction T:** allows semi-automatic solids removal for the hard-to-get-at pump well area when vertical pumps are utilized.
6. **Consolidator:** patented, vertical separation module assists chemical flotation programs. Automatic, self-cleaning design incorporates durable, reliable components. Aeration can be provided from the ALSI CheckMark™ Dewatering Vacuum Filter.
7. **ALSI CheckMark™ Sludge Dryer:** produces dewatered sludge with low energy consumption which can be costly.

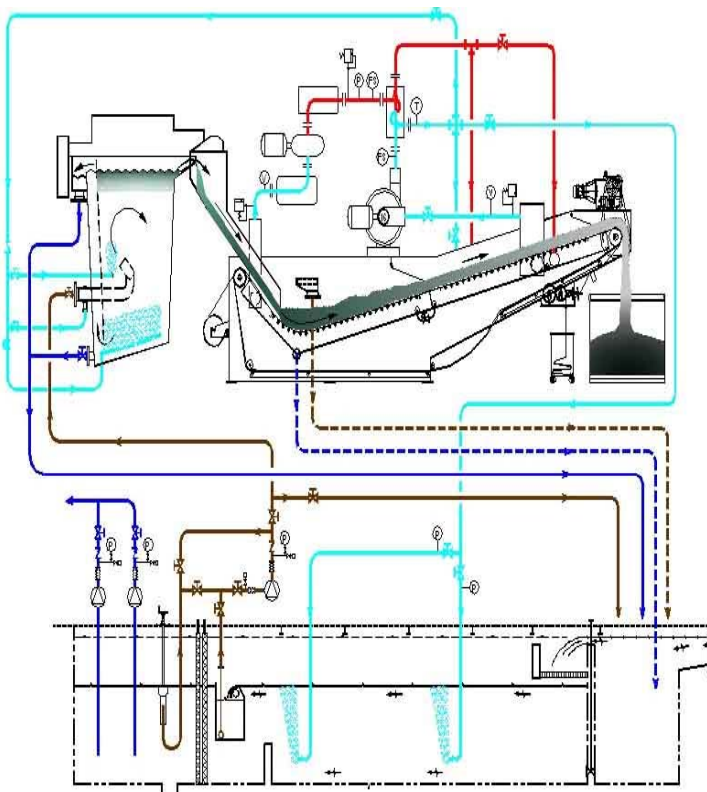

### ALSI Performance:

- Removal efficiency to 90%
- Dewatering to 70% plus by weight
- Controlled energy recovered heat source up to 140°F for consistent heat source.
- Automatic operation with minimal operator intervention

1680 S. Livernois Rd • Suite #200 • Rochester Hills, MI 48307  
Tel: 248-656-3610 • Fax: 248-656-3620 • Toll Free: 1-866-656-3611  
[www.airliquidsystems.com](http://www.airliquidsystems.com)

# ALSI CheckMark™ Hybrid Design Sludge Dryer

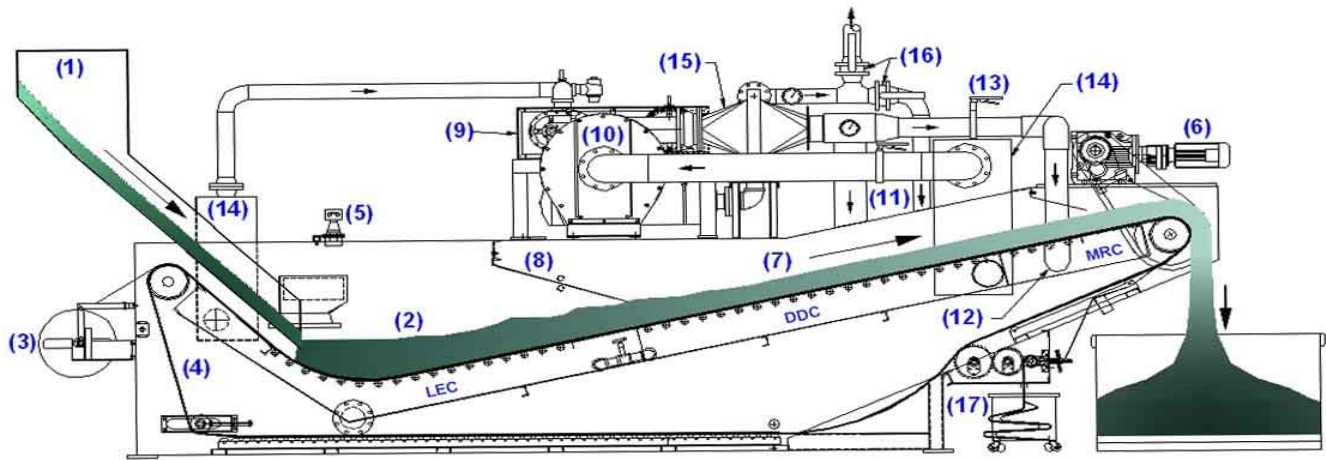

✓ **Liquid Extraction Chamber's (LEC)** deep pool provides substantial buffer for variable sludge feed rates and adequate residence time for solids coagulation and the wicking away of free water.

✓ **Dry Down Chamber (DDC)** enhances water removal utilizing warm air flow down and across the sludge cake producing dewatering efficiencies as high as 75% by weight.

✓ **Media Release Chamber (MRC) (12)** aerates the filter media from below, drying the sludge and allowing release and separate disposal of sludge and media.

✓ **Sludge Dryer (11):** Consolidated paint sludge enters the LEC (1) and continues to coagulate via polymer chemistry (2) on top of porous replaceable media (3) that is supported by a permanent flat wire belt (4) and unique side seal to contain paint sludge and minimize maintenance.

As sludge cake builds to optimum depth and density the automatic level control (5) initiates the automatic belt/media index cycle. The media drive motor (6) is energized and as clean media is pulled into the system, the media with drying sludge rides up the heated drying ramp (7) into the DDC.

## ✓ Options

Owner Specified Control System  
Media Separator, Motor Disconnects,  
Stainless Steel Wetted Surfaces Construction  
Auxiliary Heat: Infrared, Steam, Hot Water Coil  
Gravity and Single Vacuum Designs Available

The adjustable doctor blade (8) sets the depth and spreads the sludge cake, assuring even heated vacuum air drying. The unique dewatering/drying force for the ALSI CheckMark™ drying system is driven by a low pressure compressor (9) extracting liquid from the LEC chamber. The inlet side of the compressor is protected by a stainless steel (14) mist eliminator.

A second low pressure/high volume vacuum producer (10) extracts moisture from the DDC. This vacuum producer is also protected by a stainless steel mist eliminator (14).

The high temperature/low volume air flow (11) from the low pressure compressor (9) transfers heat to the high volume/low pressure vacuum producer via a special heat exchanger (15). Constant drying temperature is controlled through two valves (16). By controlling the discharge pressure of the low pressure compressor a constant temperature is maintained for sludge drying.

A separate valve (16) allows excess air to be utilized for recirculation tank/pit aeration or consolidator aerations as the overall system demands.

## Other ALSI Liquid Products:

- Autoweir (Patented)
- Sludge Consolidator (Patented)
- Gravity Filter
- Membrane Filtration
- Phosphate Filtration
- Hydrocyclones/Tore Technology
- Dewatering Bags & Media